



FOR LEASE

780 S. Van Buren Street, Unit C
Placentia, CA

1,400 SF Industrial Unit

SITE HIGHLIGHTS:

- Exterior Security Lights
- Nicely Landscaped
- LED Lights in Units
- 100 Amps, 3 Phase, 4 Wire
- 18 Foot Ceiling Clearance
- Office has A/C

UNIT FEATURES:

- Bonus Mezzanine
- LVP Flooring

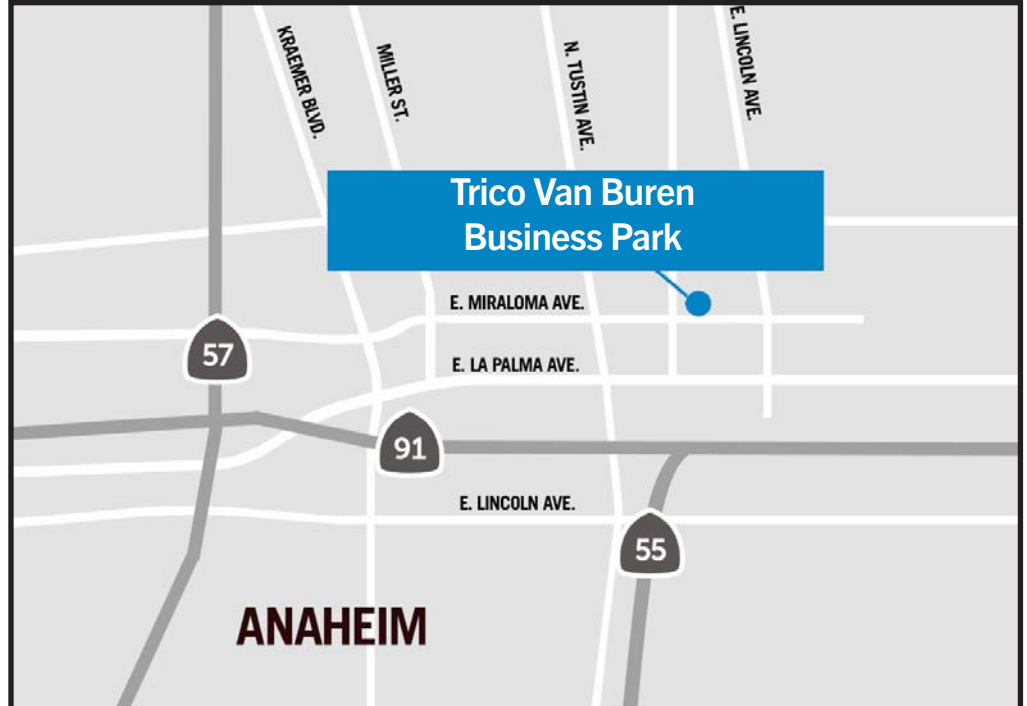

FOR FURTHER DETAILS:

JOHN PAK

john@tricoREALTY.com
License #01483069

This information has been furnished from sources which we deem reliable; however, we do not guarantee its accuracy and assume no liability. Do not rely on any of the information contained herein without verifying it yourself directly with the listing broker or owner.

Trico Realty, Inc.
License #00342120

3100-A Pullman Street
Costa Mesa, CA 92626

714-751-4420
TricoRealty.com

Unit Features

 Power: 100A | 120/208

 Clearance Height: 18'

 Ground Level Doors: One 12'x12'

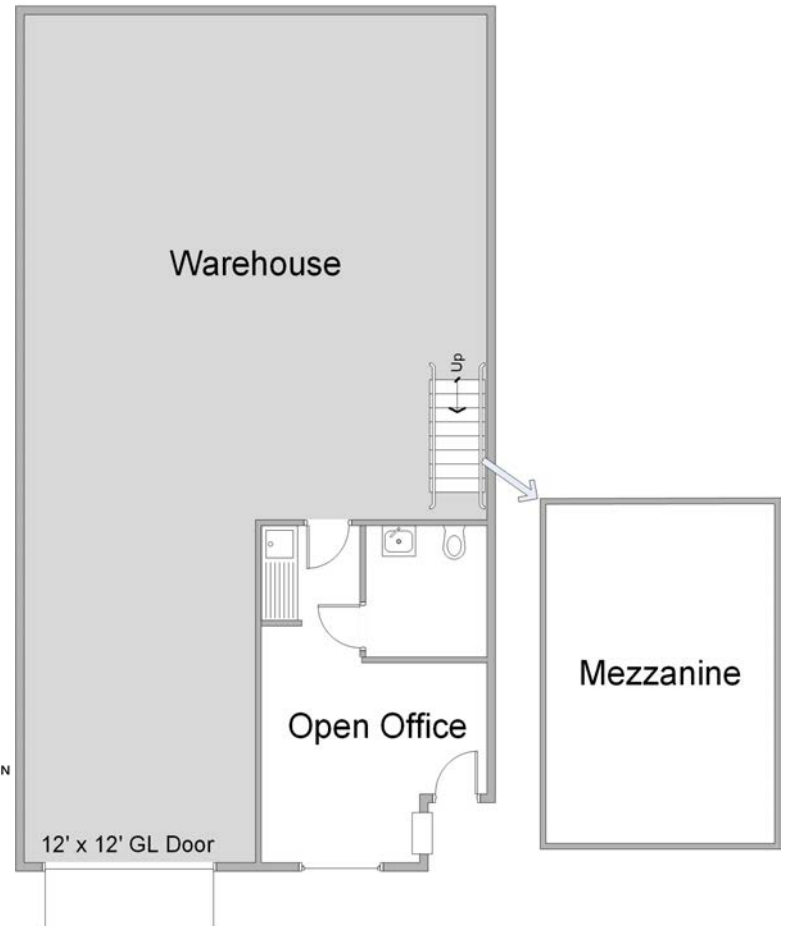
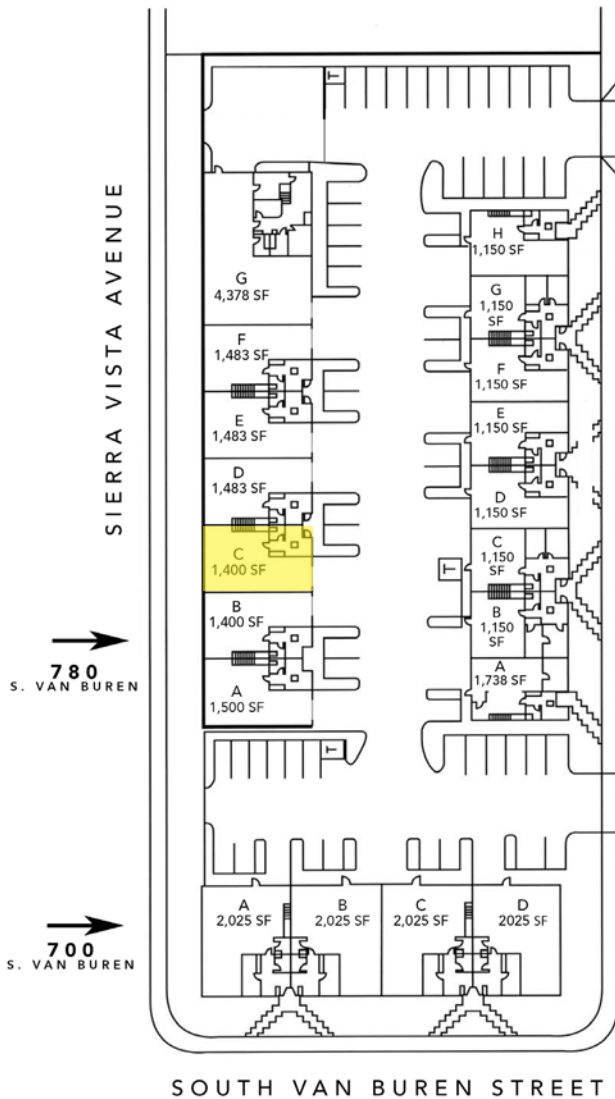

*Floorplans Not to Scale